

THE MOST COMPREHENSIVE INDUSTRIAL SOLUTION FOR FORGED STEEL AND CAST STEEL BALL, GATE, GLOBE, CHECK, PLUG, BUTTERFLY AND PIG VALVES

COMPLETE SOLUTIONS

YOU CAN TRUST



CFFT CHENGFENG FLOW-TECH GROUP

CHV®

FULLY WELDED BALL VALVES FOR URBAN GAS AND SKID MOUNT



CHENGFENG FLOW-TECH GROUP

www.china-cfft.com

China Headquarters
No. 6, Guanghua Road Jinyuan Town, Dayi County,
Chengdu City, Sichuan Province, China
Tel: +86(28)87465186
Fax: +86(28)84847510
E-mail: sales@china-cfft.com

USA Office
10700 Richmond Ave Ste 230
Houston, TX 77042
Tel: +1(832)831-2473
Fax: +1(832)831-2617
E-mail: international@china-cfft.com

CHV-PW-1601

CHV INTERNATIONAL, INC.
CHENGDU CHENGGAO VALVE CO., LTD.
CHENGDU CHENGFENG VALVE CO., LTD.

PROFILE

CHENGFENG FLOW-TECH GROUP

Chengfeng Flow-Tech Group, headquartered in Chengdu, China, is the leading flow technology company in China. Being a high-tech group specialized in R&D, manufacturing of industrial valves, and being one of the core suppliers to Petro-China, SINOPEC and CNOOC for decades, it has transformed into a multi-dimensional group that is committed to providing the most complete solutions to the oil&gas markets. With industry-leading facilities, innovative technical teams and highly professional engineers, its top-notch services cover various realms in the energy sector – valve manufacturing and maintenance, fluids equipment solutions, flow control solutions and industrial data analytics, etc.

Chengfeng's products have been widely used in the oil&gas pipelines, petrochemical industries, aerospace industry and power stations, etc. Chengfeng's top two brands, CHV and CCFV, have established the nationwide reputation for their quality and service. Now, Chengfeng Flow-Tech Group has begun its new adventure – serving the world market.

CHENGDU CHENGGAO VALVE CO., LTD. (CHV)

CHV was founded in 1993, and has been specialized in the R&D and manufacturing of mid&high end ball valves ever since. CHV offers complete ball valve product lines. Among all the product lines, the High Pressure Large Diameter Fully Welded Ball Valves have captured more than half the domestic fully welded ball valve market. High Temperature Metal-Seated Oxygen Ball Valve and NACE Ball Valve are also leading the domestic market.

CHENGDU CHENGFENG VALVE CO., LTD. (CCFV)

CCFV was founded in 1966. Its main product lines include slab gate valves, expanding gate valves, tri-eccentric butterfly valves, check valves, globe valves and plug valves, etc. CCFV is leading the domestic slab gate valve market, taking up 70% of the oil transportation and storage sector.

CHV INTERNATIONAL, INC.

CHV International, Inc. is the newest branch of Chengfeng Flow-Tech Group. Based in Houston, Texas, U.S.A, its mission is to shorten the distance between the Group and the international market by providing faster response and better service to our customers around the globe.

CERTIFICATION

Chengfeng Flow-Tech Group's quality program is fully compliant with the industry's most stringent standards. The group holds all major certifications, including but not limited to API 6D, ISO 9001, ISO 14001, OHS 18001, CE, API 6FA, API 607 fire safety inspection certificate.

CONTENTS

PROFILE	1
T50 SERIES DESIGN FEATURES	2~3
T51 SERIES DESIGN FEATURES	4
T50 SERIES PARTS LIST	5
T51 SERIES PARTS LIST	6
DIMENSIONS & WEIGHTS	7~8
HOW TO ORDER	9~10



T50 SERIES DESIGN FEATURES

FULLY WELDED TRUNNION BALL VALVES FOR URBAN GAS AND SKID MOUNT

RANGE & STANDARD

Size	NPS 6–32 (DN 150–800)
Pressure	ASME Class150–600
Temperature	–50°F~250°F (–46°C~121°C)
Design Standard	API 6D
Test Standard	API 6D, API 598
End Connection	ASME B16.5, ASME B16.47, MS SP–44, ASME B31.8, ASME B16.25, etc.
Face-to-Face	API 6D, ASME B16.10
Fire Test	API 6FA, API 607
Anti-Corrosion, Acid-Resisting *	NACE MR0103, NACE MR0175, ISO 15156

*Optional, available upon request.

LOW EMISSION VALVES

Accurate machining of stem and bonnet sealing surfaces ensures compliance with the most severe pollution control regulations. Special "live" seals are available on request.

INDEPENDENT BALL AND STEM

The ball and stem are independent to minimize the effect of the side thrust generated by the pressure acting on the ball.

ANTI-STATIC DESIGN

The electrical conductance continuity between all the metallic components is guaranteed and certified.

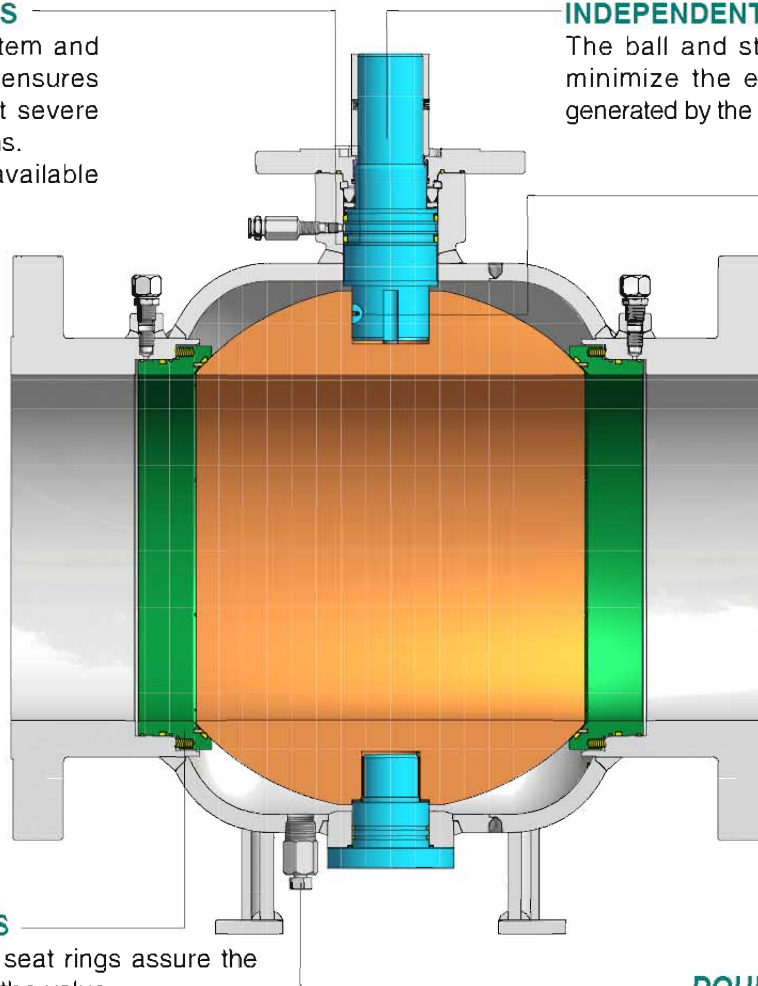

FLOATING SEAT RINGS

Two independent floating seat rings assure the bi-directional tightness of the valve. The seats are carefully designed to minimize the torque required to operate the valves without losing sealing power, which is assured from zero differential pressure to the valve's maximum rated pressure.

DOUBLE BLOCK & BLEED

The double block and bleed feature, both with the ball in the fully closed or fully open position, is a standard feature.

Self-relieving seats are supplied as a standard feature.

Double piston or combination seats (self-relieving/ upstream, double piston/downstream) can be supplied on request.

T50 SERIES DESIGN FEATURES

FULLY WELDED TRUNNION BALL VALVES FOR URBAN GAS AND SKID MOUNT

BALL SEAT ALIGNMENT

Mechanical stops ensure control over ball rotation.

ANTI-BLOWOUT STEM

Stem is retained by the stem cover. Other designs available on request.

EMERGENCY SEALANT INJECTION

Each valve is supplied c/w emergency sealant injection feature located between the upper O-rings and the graphite gasket. And each of the injection valve will install with check valve. Emergency sealant injection feature on seats is available on request only, for 6" full port and larger. Emergency grease injection features are not available on low and high temperature valves.

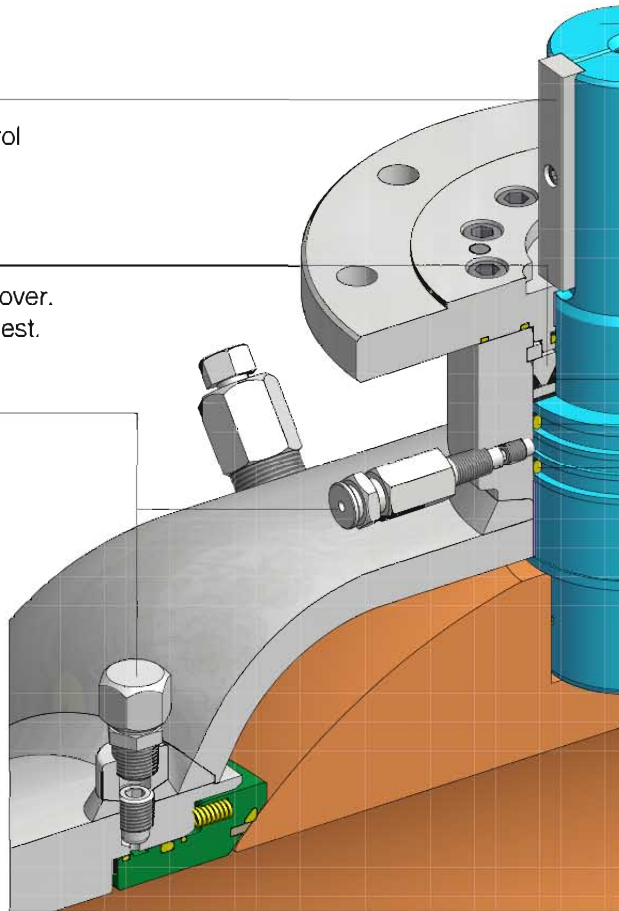

VALVE POSITION INDICATOR

The stem's slotted direction is the same with the ball's bore direction. Easily identify open/closed position.

STEM SEALING

Two O-rings and one graphite gasket ensure the stem seal. The graphite gasket can be replaced while the valve is under pressure and with the ball in any position, by removing the adaptor plate, after having released any pressure that may exist between the upper O-ring and the graphite gasket, through the grease injection fitting hole. The O-rings can be replaced with the valve in fully open or fully closed position by removing the stem cover after having released all the pressure in the body cavity.

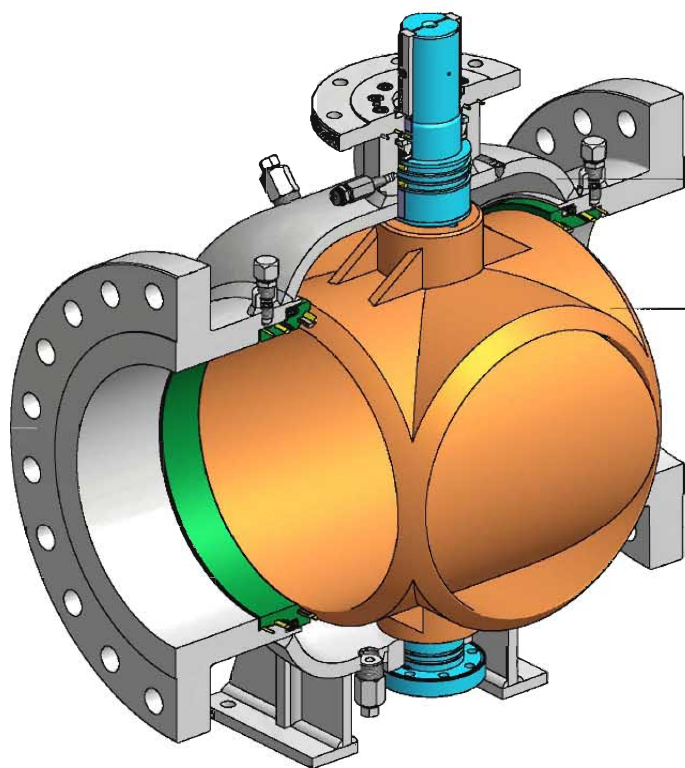

FULLY WELDED BODY

Body molded by steel pipe necking has the advantage of light weight and high material utilization. Body is fully welded. Body / end cap and body / gland are also connected by welding. The elimination of bolt connections reduces leak point on the valve.

CROSS BALL

Cross ball molded by the cross welded pipes has the advantage of light weight and self-cleaning capability, when the valve is in closed status, impurities contacting sealing surface is avoided, and thereby sealing surface is protected.

SOLID BALL

Conventional solid ball machined by forging processing, with high rigidity and without the defect such as segregation, stomata and slag.

T51 SERIES DESIGN FEATURES

FULLY WELDED FLOATING BALL VALVES FOR URBAN GAS AND SKID MOUNT

RANGE & STANDARD

Size	NPS 1–8 (DN 25–200)
Pressure	ASME Class 150–600
Temperature	–50°F–250°F (–46°C–121°C)
Design Standard	ISO 17292
Test Standard	ISO 17292, API 598
End Connection	ASME B16.5, ASME B31.8, ASME B16.25, etc.
Face-to-Face	ASME B16.10
Fire Test	API 6FA, API 607
Anti-Corrosion, Acid-Resisting*	NACE MR0103, NACE MR0175, ISO 15156

*Optional, available upon request.

ANTI-BLOWOUT STEM

Stem is retained by the stem cover. Other designs available on request.

ANTI-STATIC DESIGN

The electrical conductance continuity between all the metallic components is guaranteed and certified.

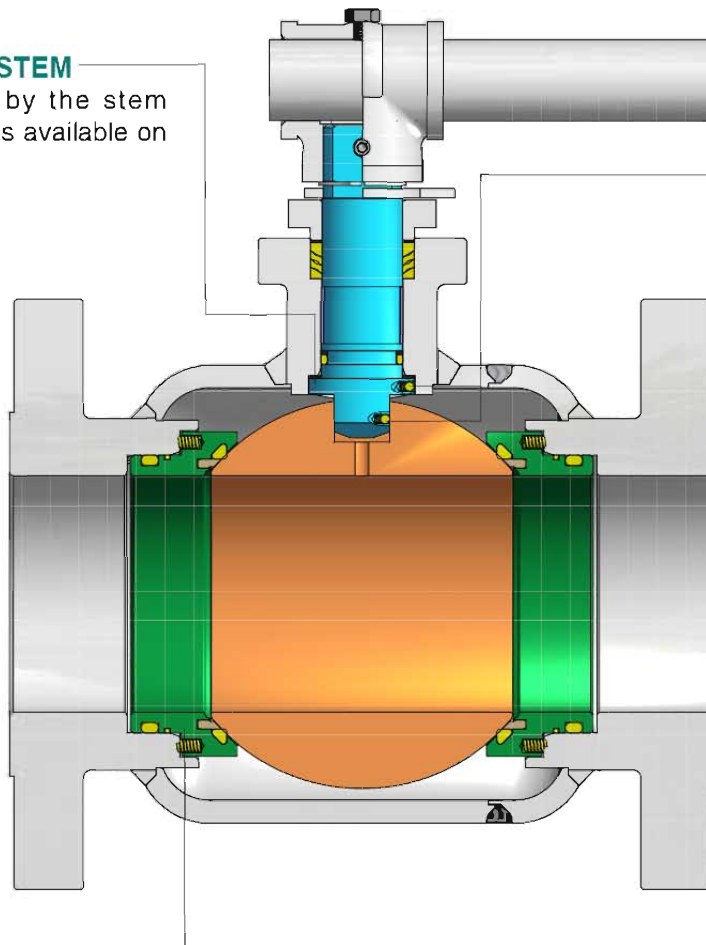

FLOATING SEAT RINGS

Two independent floating seat rings assure the bi-directional tightness of the valve. The seats are carefully designed to minimize the torque required to operate the valves without losing sealing power, which is assured from zero differential pressure to the valve's maximum rated pressure.

T50 SERIES PARTS LIST

FULLY WELDED TRUNNION BALL VALVES FOR URBAN GAS AND SKID MOUNT			
1	Body	15*	Triangle Packing
2	End Cap	16	Thrust Bearing
3	Gland	17	Thrust Washer
4	Ball	18a	Sliding Bearing
5	Stem	18b	Sliding Bearing
6	Trunnion	18c	Sliding Bearing
7	Seat	19	Key
8	Scraper	20	Anti-static Device
9	Adapter Plate	21	Coil Spring
10	Four-piece Ring	22	Head Bolt
11	V-type Packing Ring	23	Check Valve
12	Seat Insert	24	Grease Injection Valve
13a	O-ring	25	Drain Valve
13b*	O-ring	26	Support Leg
13c*	O-ring	27	Vent Valve
14*	Spiral Wound Gasket		

* Recommended spare parts.

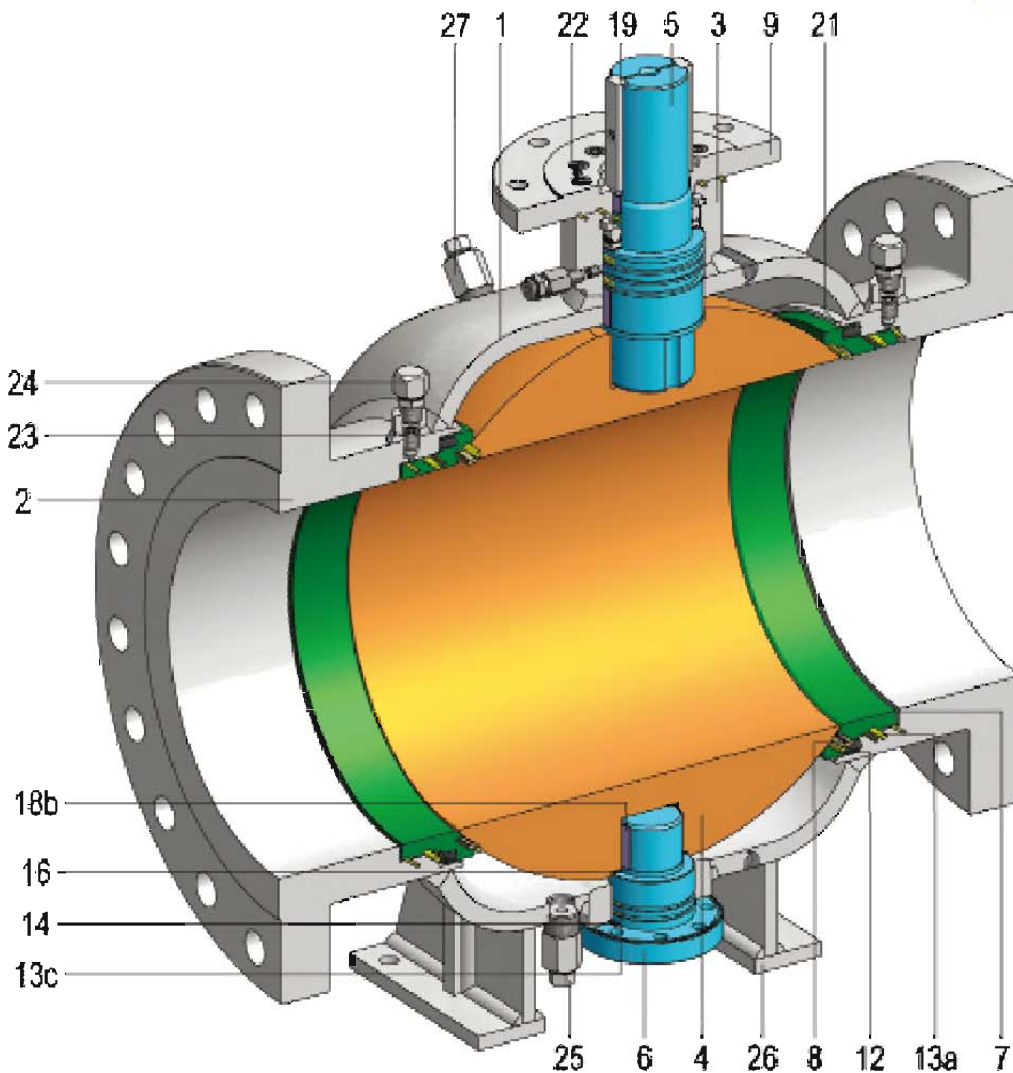
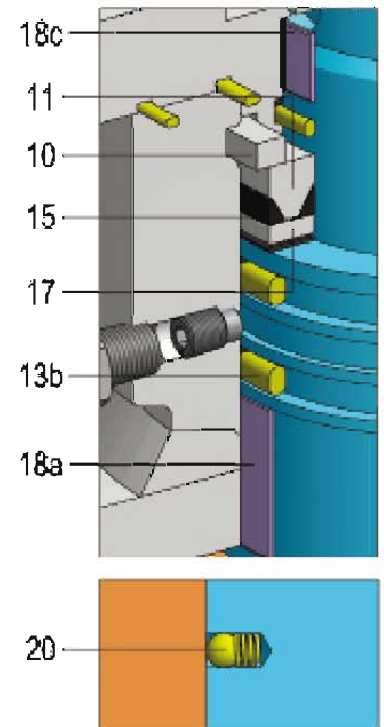

T51 SERIES PARTS LIST

FULLY WELDED FLOATING BALL VALVES FOR URBAN GAS AND SKID MOUNT

1	Body	13	Thrust Bearing
2	End Cap	14	Sliding Bearing
3	Gland	15	Coil Spring
4	Ball	16a	Anti-static Device
5	Stem	16b	Anti-static Device
6	Seat	17a	Bolt
7	Scraper	17b	Bolt
8	Gland Flange	18	Stopper
9	Seat Insert	19	Connector
10a	O-ring	20	Handle
10b	O-ring	21	Set Screw
11*	Combined Packing	22	Snap Ring
12*	Rectangular Packing		

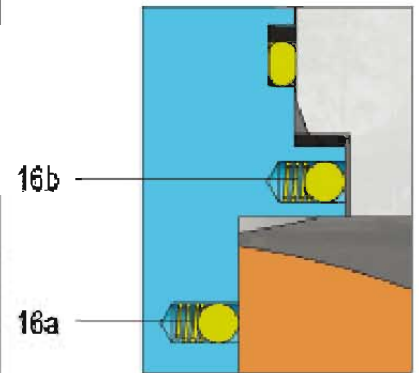

* Recommended spare parts.

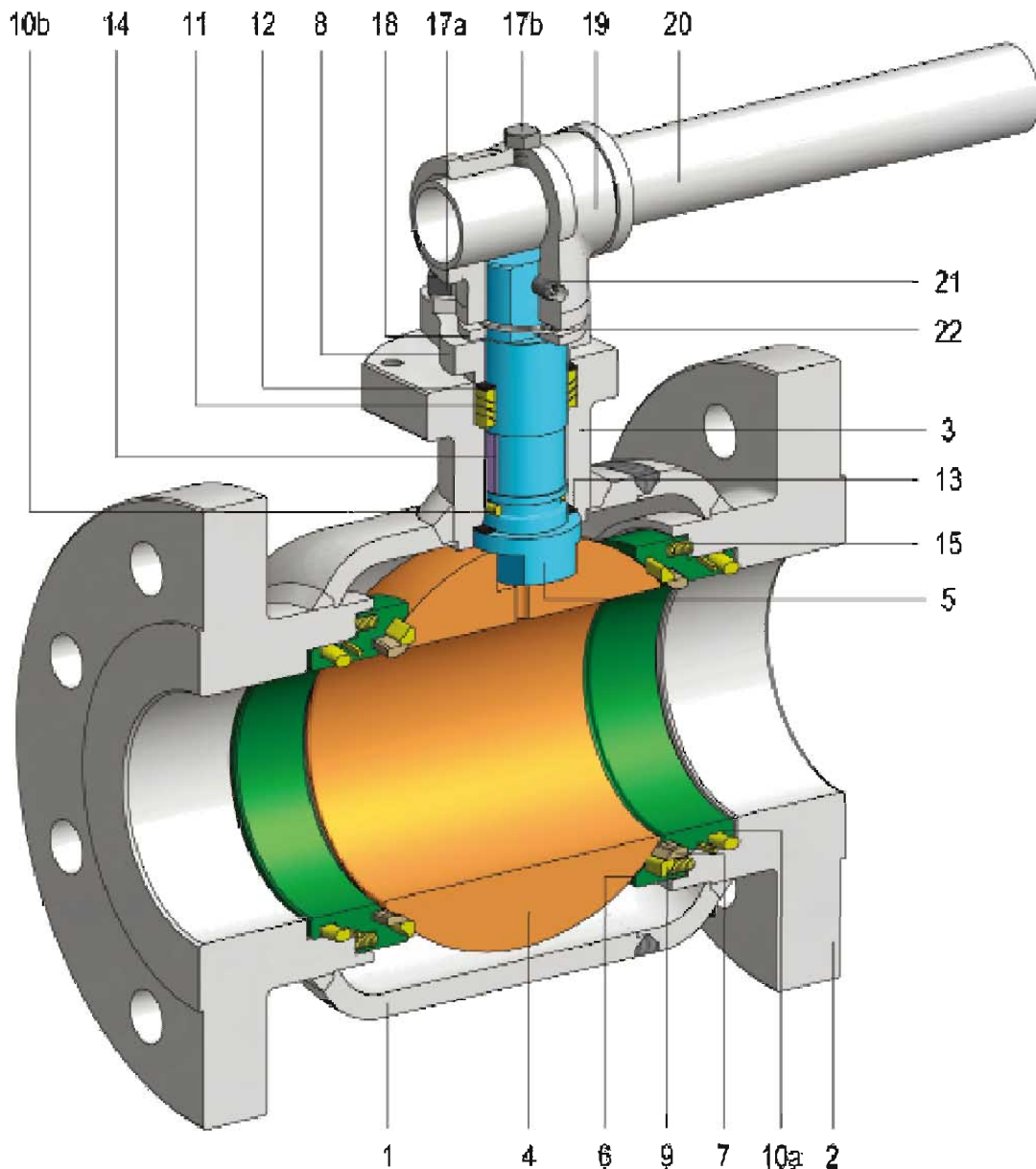

DIMENSIONS & WEIGHTS

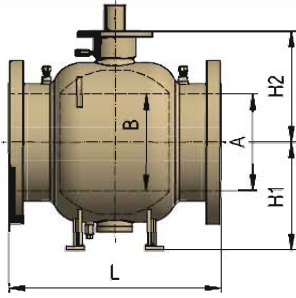

T50 Series

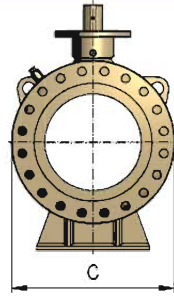

T51 Series

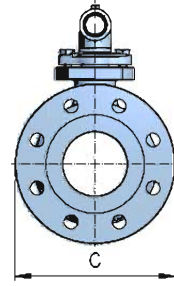
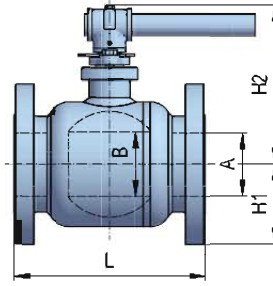

ASME CLASS 150 FULL BORE

Size		A		B		L-RF		L-BW		H1		H2		C		Weight*		Series	
NPS	DN	in	mm	in	mm	in	mm	in	mm	in	mm	in	mm	in	mm	lb	kg		
1	25	1.00	25	1.00	25	5.00	127	①	①	1.38	35	4.41	112	4.33	110	13	6	T51	
1-1/2	40	1.50	38	1.50	38	6.50	165	0.30	7.5	1.61	41	5.20	132	4.92	125	18	8	T51	
2	50	1.94	49	1.94	49	7.00	178	8.50	216	1.89	48	5.51	140	5.91	150	33	15	T51	
3	80	2.94	74	2.94	74	8.00	203	11.13	283	2.80	71	5.98	152	7.48	190	60	27	T51	
4	100	3.94	100	3.94	100	9.00	229	12.00	305	3.70	94	8.66	220	9.06	230	120	55	T51	
6	150	5.94	150	5.94	150	15.50	394	18.00	457	9.37	238	11.38	289	11.02	280	212	96	T51	
8	200	7.94	201	7.94	201	18.00	457	20.50	521	10.87	276	11.69	297	13.86	352	235	107	T51	
6	150	5.94	150	5.94	150	15.50	394	18.00	457	9.65	245	9.49	241	11.02	280	218	99	T50	
8	200	7.94	201	7.94	201	18.00	457	20.50	521	10.83	275	11.59	294.5	13.86	352	353	160	T50	
10	250	9.94	252	9.94	252	21.00	533	22.00	559	12.80	325	13.31	338	16.97	431	560	255	T50	
12	300	11.94	303	11.94	303	24.00	610	25.00	635	14.47	367.5	15.20	386	20.20	513	847	385	T50	
14	350	13.19	334	13.19	334	27.00	686	30.00	762	15.35	390	16.04	407.5	22.05	560	1036	471	T50	
16	400	15.19	385	15.19	385	30.00	762	33.00	838	16.93	430	17.40	442	24.96	634	1453	660	T50	
18	450	17.19	436	17.19	436	34.00	864	36.00	914	18.54	471	20.08	510	28.43	722	1669	759	T50	
20	500	19.19	487	19.19	487	36.00	914	39.00	991	20.43	519	22.32	567	31.42	798	1872	851	T50	
22	550	①	①	①	①	①	①	①	①	①	①	①	①	①	①	①	①	①	T50
24	600	23.19	589	23.19	589	42.00	1067	45.00	1143	23.66	601	25.91	658	37.83	961	3118	1417	T50	
28	700	26.94	684	26.94	684	49.00	1245	53.00	1346	26.81	681	34.06	865	43.35	1101	4625	2102	T50	
32	800	30.69	779	30.69	779	54.00	1372	60.00	1524	30.04	763	34.06	865	49.84	1266	6360	2891	T50	

ASME CLASS 300 FULL BORE

Size		A		B		L-RF		L-BW		H1		H2		C		Weight*		Series	
NPS	DN	in	mm	in	mm	in	mm	in	mm	in	mm	in	mm	in	mm	lb	kg		
1	25	1.00	25	1.00	25	6.50	165	—	—	1.38	35	4.41	112	4.92	125	15	7	T51	
1-1/2	40	1.50	38	1.50	38	7.48	190	7.48	190	1.61	41	5.20	132	6.10	155	20	9	T51	
2	50	1.94	49	1.94	49	8.50	216	8.50	216	1.89	48	5.51	140	6.50	165	35	16	T51	
3	80	2.94	74	2.94	74	11.13	283	11.13	283	2.80	71	5.98	152	8.27	210	64	29	T51	
4	100	3.94	100	3.94	100	12.00	305	12.00	305	3.70	94	8.66	220	10.04	255	128	58	T51	
6	150	5.94	150	5.94	150	15.88	403	18.00	457	9.37	238	11.38	289	12.60	320	224	102	T51	
8	200	7.94	201	7.94	201	19.75	502	20.50	521	10.87	276	11.69	297	14.96	380	249	113	T51	
6	150	5.94	150	5.94	150	15.88	403	18.00	457	9.65	245	9.49	241	12.60	320	231	105	T50	
8	200	7.94	201	7.94	201	19.75	502	20.50	521	10.83	275	11.59	294.5	14.96	380	374	170	T50	
10	250	9.94	252	9.94	252	22.38	568	22.00	559	12.80	325	13.31	338	17.52	445	594	270	T50	
12	300	11.94	303	11.94	303	25.50	648	25.00	635	14.47	367.5	15.20	386	20.47	520	898	408	T50	
14	350	13.19	334	13.19	334	30.00	762	30.00	762	15.35	390	16.04	407.5	23.03	585	1098	499	T50	
16	400	15.19	385	15.19	385	33.00	838	33.00	838	16.93	430	17.40	442	25.59	650	1540	700	T50	
18	450	17.19	436	17.19	436	36.00	914	36.00	914	18.54	471	20.08	510	28.43	722	1769	804	T50	
20	500	19.19	487	19.19	487	39.00	991	39.00	991	20.43	519	22.32	567	31.42	798	1984	902	T50	
22	550	①	①	①	①	①	①	①	①	①	①	①	①	①	①	①	①	①	T50
24	600	23.19	589	23.19	589	45.00	1143	45.00	1143	23.66	601	25.91	658	37.83	961	3304	1502	T50	
28	700	26.94	684	26.94	684	53.00	1346	53.00	1346	26.81	681	34.06	865	43.35	1101	4902	2228	T50	
32	800	30.69	779	30.69	779	60.00	1524	60.00	1524	30.04	763	34.06	865	49.84	1266	6741	3064	T50	

ASME CLASS 600 FULL BORE

Size		A		B		L-RF		L-BW		H1		H2		C		Weight*		Series
NPS	DN	in	mm	in	mm	in	mm	in	mm	in	mm	in	mm	in	mm	lb	kg	
6	150	5.94	150	5.94	150	22.00	559	22.00	559	9.61	244	10.75	273	12.60	320	464	211	T50
8	200	7.94	201	7.94	201	26.00	660	26.00	660	11.10	282	12.64	321	14.96	380	486	221	T50
10	250	9.94	252	9.94	252	31.00	787	31.00	787	12.80	325	14.33	364	17.68	449	658	299	T50
12	300	11.94	303	11.94	303	33.00	838	33.00	838	14.92	379	16.42	417	21.14	537	1012	460	T50
14	350	13.19	334	13.19	334	35.00	889	35.00	889	15.75	400	17.28	439	23.03	585	1551	705	T50
16	400	15.19	385	15.19	385	39.00	991	39.00	991	17.52	445	19.53	496	26.14	664	2189	995	T50
18	450	17.19	436	17.19	436	43.00	1092	43.00	1092	19.13	486	21.57	548	29.61	752	3206	1457	T50
20	500	19.19	487	19.19	487	47.00	1194	47.00	1194	21.22	539	23.46	596	32.99	838	4153	1888	T50
22	550	21.19	538	21.19	538	51.00	1295	51.00	1295	23.03	585	25.28	642	36.57	929	5483	2492	T50
24	600	23.19	589	23.19	589	55.00	1397	55.00	1397	24.65	626	32.28	820	39.80	1011	6738	3063	T50
28	700	26.94	684	26.94	684	61.00	1549	61.00	1549	27.99	711	35.24	895	45.71	1161	10250	4659	T50
32	800	30.69	779	30.69	779	70.00	1778	70.00	1778	31.22	793	35.24	895	52.20	1326	14019	6372	T50

* Weight figures are relevant to flanged end valves. ① Please consult the factory.

Note: For dimensions & weights in larger sizes consult the factory.

Dimensions and weights are subject to change without notice.

Face to face dimensions not listed in industry standards are subject to change without notice.

DIMENSIONS & WEIGHTS

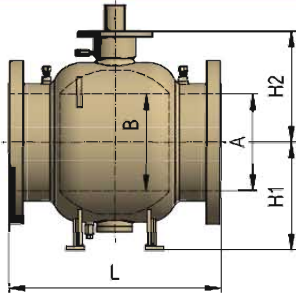

T50 Series

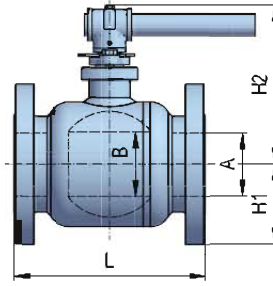
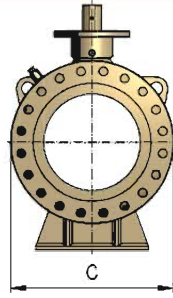

T51 Series

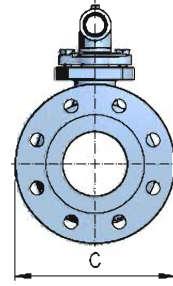

ASME CLASS 150 REDUCED BORE

Size		A		B		L-RF		L-BW		H1		H2		C		Weight*		Series
NPS	DN	in	mm	in	mm	in	mm	in	mm	in	mm	in	mm	in	mm	lb	kg	
2 x 1-1/2	50 x 40	1.94	49	1.50	38	7.00	178	8.50	216	1.61	41	5.20	132	5.91	150	15.4	7	T51
3 x 2	80 x 50	2.94	74	1.94	49	8.00	203	11.13	283	1.89	48	5.51	140	7.48	190	33	15	T51
4 x 3	100 x 80	3.94	100	2.94	74	9.00	229	12.00	305	2.80	71	5.98	152	9.06	230	57.2	26	T51
6 x 4	150 x 100	5.94	150	3.94	100	15.50	394	18.00	457	3.70	94	8.66	220	11.02	280	116.6	53	T51
8 x 6	200 x 150	7.94	201	5.94	150	18.00	457	20.50	521	9.37	238	11.38	289	13.58	345	202.4	92	T51
10 x 8	250 x 200	9.94	252	7.94	201	21.00	533	22.00	559	10.87	276	11.69	297	15.94	405	224.4	102	T51
8 x 6	200 x 150	7.94	201	5.94	150	18.00	457	20.50	521	9.65	245	9.49	241	13.58	345	238	108	T50
10 x 8	250 x 200	9.94	252	7.94	201	21.00	533	22.00	559	10.83	275	11.59	294.5	15.94	405	384	175	T50
12 x 10	300 x 250	11.94	303	9.94	252	24.00	610	25.00	635	12.80	325	13.31	338	19.09	485	613	278	T50
14 x 12	350 x 300	13.19	334	11.94	303	27.00	686	30.00	762	14.47	367.5	15.20	386	21.06	535	925	420	T50
16 x 14	400 x 350	15.19	385	13.19	334	30.00	762	33.00	838	15.35	390	16.04	407.5	23.43	595	1131	514	T50
20 x 16	500 x 400	19.19	487	15.19	385	36.00	914	39.00	991	16.93	430	17.40	442	27.56	700	1585	721	T50
20 x 18	500 x 450	19.19	487	17.19	436	36.00	914	39.00	991	18.54	471	20.08	510	28.43	722	1823	829	T50
24 x 20	600 x 500	23.19	589	19.19	487	42.00	1067	45.00	1143	20.43	519	22.32	567	32.09	815	2044	929	T50
28 x 24	700 x 600	26.94	684	23.19	589	49.00	1245	53.00	1346	23.66	601	25.91	658	37.83	961	3454	1570	T50
32 x 28	800 x 700	30.69	779	26.94	684	54.00	1372	60.00	1524	26.81	681	34.06	865	43.35	1101	5049	2295	T50

ASME CLASS 300 REDUCED BORE

Size		A		B		L-RF		L-BW		H1		H2		C		Weight*		Series
NPS	DN	in	mm	in	mm	in	mm	in	mm	in	mm	in	mm	in	mm	lb	kg	
2 x 1-1/2	50 x 40	1.94	49	1.50	38	8.50	216	8.50	216	1.61	41	5.20	132	6.50	165	24	11	T51
3 x 2	80 x 50	2.94	74	1.94	49	11.13	283	11.13	283	1.89	48	5.51	140	8.27	210	40	18	T51
4 x 3	100 x 80	3.94	100	2.94	74	12.00	305	12.00	305	2.80	71	5.98	152	10.04	255	89	41	T51
6 x 4	150 x 100	5.94	150	3.94	100	15.88	403	18.00	457	3.70	94	8.66	220	12.60	320	180	82	T51
8 x 6	200 x 150	7.94	201	5.94	150	19.75	502	20.50	521	9.37	238	11.38	289	14.96	380	398	181	T51
10 x 8	250 x 200	9.94	252	7.94	201	22.38	568	22.00	559	10.87	276	11.69	297	17.52	445	449	204	T51
8 x 6	200 x 150	7.94	201	5.94	150	19.75	502	20.50	521	9.65	245	9.49	241	14.96	380	426	194	T51
10 x 8	250 x 200	9.94	252	7.94	201	22.38	568	22.00	559	10.83	275	11.59	294.5	17.52	445	475	216	T50
12 x 10	300 x 250	11.94	303	9.94	252	25.50	648	25.00	635	12.80	325	13.31	338	20.47	520	647	294	T50
14 x 12	350 x 300	13.19	334	11.94	303	30.00	762	30.00	762	14.47	367.5	15.20	386	23.03	585	970	441	T50
16 x 14	400 x 350	15.19	385	13.19	334	33.00	838	33.00	838	15.35	390	16.04	407.5	25.59	650	1265	575	T50
20 x 16	500 x 400	19.19	487	15.19	385	39.00	991	39.00	991	16.93	430	17.40	442	30.51	775	1712	778	T50
20 x 18	500 x 450	19.19	487	17.19	436	39.00	991	39.00	991	18.54	471	20.08	510	30.51	775	1965	893	T50
24 x 20	600 x 500	23.19	589	19.19	487	45.00	1143	45.00	1143	20.43	519	22.32	567	36.02	915	2200	1000	T50
28 x 24	700 x 600	26.94	684	23.19	589	53.00	1346	53.00	1346	23.66	601	25.91	658	40.75	1035	3665	1666	T50
32 x 28	800 x 700	30.69	779	26.94	684	60.00	1524	60.00	1524	26.81	681	34.06	865	45.28	1150	5373	2442	T50

ASME CLASS 600 REDUCED BORE

Size		A		B		L-RF		L-BW		H1		H2		C		Weight*		Series
NPS	DN	in	mm	in	mm	in	mm	in	mm	in	mm	in	mm	in	mm	lb	kg	
8 x 6	200 x 150	7.94	201	5.94	150	26.00	660	26.00	660	9.61	244	10.75	273	14.96	380	509	231	T50
10 x 8	250 x 200	9.94	252	7.94	201	31.00	787	31.00	787	11.10	282	12.64	321	17.52	445	537	244	T50
12 x 10	300 x 250	11.94	303	9.94	252	33.00	838	33.00	838	12.80	325	14.33	364	20.47	520	735	334	T50
14 x 12	350 x 300	13.19	334	11.94	303	35.00	889	35.00	889	14.92	379	16.42	417	23.03	585	1119	509	T50
16 x 14	400 x 350	15.19	385	13.19	334	39.00	991	39.00	991	15.75	400	17.28	439	25.59	650	1704	775	T50
20 x 16	500 x 400	19.19	487	15.19	385	47.00	1194	47.00	1194	17.52	445	19.53	496	30.51	775	2447	1112	T50
20 x 18	500 x 450	19.19	487	17.19	436	47.00	1194	47.00	1194	19.13	486	21.57	548	30.51	775	3603	1638	T50
24 x 20	600 x 500	23.19	589	19.19	487	55.00	1397	55.00	1397	21.22	539	23.46	596	36.02	915	4553	2069	T50
28 x 24	700 x 600	26.94	684	23.19	589	61.00	1549	61.00	1549	24.65	626	32.28	820	42.32	1075	7533	3424	T50
32 x 28	800 x 700	30.69	779	26.94	684	70.00	1778	70.00	1778	27.99	711	35.24	895	47.05	1195	11418	5190	T50

* Weight figures are relevant to flanged end valves.

Note: For dimensions & weights in larger sizes consult the factory.

Dimensions and weights are subject to change without notice.

Face to face dimensions not listed in industry standards are subject to change without notice.

HOW TO ORDER

PLEASE PROVIDE FOLLOWING INFORMATION :

1. Max./Min. Operating Pressure, Max. /Min. Service Temp, Special Flow/Service Environment Requirements.
2. Design Standard (API6D, ISO 17292, API 608 or Other).
3. Test Requirements (Standard Package, UT, PT, MT, RT, High Pressure (N2/Air), Low Emission, Low Temp. or other).
4. Other Requirements (Mating Flange, PUP, Third-party Inspection or Other).

A	B	C	D	E	F	G	H	I	J	K
MODEL	SIZE	PRESSURE RATING	CONNECTION	ACTUATION	BODY MATERIAL	SEALS	TRIM MATERIAL	TRIM COATING	BOLTS&NUTS	SPECIAL REQUIREMENTS
T50	20 × 16	150	RF	G	AQ	VV	002	1	B2	D

EXAMPLE:T50-20 × 16-150RF-G-AQVV0021B2-D

Fully welded trunnion ball valves for urban gas and skid mount, 20 × 16" reduced port, ASME 150, Flanged RF, Gear actuator, Q345R body, VITON/VITON seals, A105N trim, ENP trim coating, B7/2H bolts & nuts, Double piston effect of seat.

A		MODEL	
CODE	TYPE	CODE	TYPE
T50	Fully Welded Trunnion Ball Valves For Urban Gas And Skid Mount	T51	Fully Welded Floating Ball Valves For Urban Gas And Skid Mount

B		SIZE					
FULL BORE				REDUCED BORE			
CODE	NPS(DN)	CODE	NPS(DN)	CODE	NPS(DN)	CODE	NPS(DN)
1	1(25)	14	14(350)	2 × 1-1/2	2 × 1-1/2(50 × 40)	20 × 16	20 × 16(500 × 400)
1-1/2	1-1/2(40)	16	16(400)	3 × 2	3 × 2(80 × 50)	22 × 18	22 × 18(550 × 450)
2	2(50)	18	18(450)	4 × 3	4 × 3(100 × 80)	24 × 20	24 × 20(600 × 500)
3	3(80)	20	20(500)	6 × 4	6 × 4(150 × 100)	24 × 22	24 × 22(600 × 550)
4	4(100)	22	22(550)	8 × 6	8 × 6(200 × 150)	28 × 24	28 × 24(700 × 600)
6	6(150)	24	24(600)	10 × 8	10 × 8(250 × 200)		
8	8(200)	28	28(700)	12 × 10	12 × 10(300 × 250)		
10	10(250)	30	30(750)	14 × 12	14 × 12(350 × 300)		
12	12(300)	32	32(800)	18 × 14	18 × 14(450 × 350)		

C				D			
PRESSURE RATING				CONNECTION			
CODE	TYPE	CODE	TYPE	CODE	TYPE	CODE	TYPE
150	ASME 150	1.6P	PN 16	RF	Flanged RF-B16.5(NPS 1/2~NPS 24)	RFB	Flanged RF-B16.47(NPS 26~NPS 60) Series B
300	ASME 300	3.2P	PN 32		Flanged RF-MSS SP 44(NPS 22)	RJB	Flanged RJ-B16.47(NPS 26~NPS 60) Series B
400	ASME 400	6.4P	PN 64		Flanged RF-B16.47(NPS 26~NPS 60) Series A	SW	Socket Weld-ASME B16.11
600	ASME 600	8P	PN 80	RJ	Flanged RJ-B16.5(NPS 1/2~NPS 24)	ET	External Thread-ASME B1.20.1
		10P	PN 100		Flanged RJ-MSS SP 44(NPS 22)	BW	Butt Weld-ASME B31.8*
					Flanged RJ-B16.47(NPS 26~NPS 60) Series A	XX	Others
*For weld end valves, specify ID or OD, wall thickness and grade of pipe.							

E		ACTUATION			
CODE	TYPE	CODE	TYPE		
B	Bare Stem	S	Pneumatic-Spring Return	Type operator desired (electric, hydraulic, pneumatic), provide following information: 1. Speed of opening and closing, probable frequency of operation. 2. Accessories and controls (limit switches, valving, instrumentation, tanks, pumps, etc). 3. Information on operating medium. (If electric: voltage, frequency, single-or three-phase, open-or explosion-proof motor, If hydraulic or pneumatic: operating medium and pressure. etc.)	
W	Wrench	D	Pneumatic-Double Acting		
G	Worm Gear	M	Gas-Hydraulic		
E	Electric	N	Electro-Hydraulic		
H	Hydraulic	X	Others		

F	BODY MATERIAL							
CODE	BODY	END CONNECTION	CODE	BODY	END CONNECTION	CODE	BODY	END CONNECTION
AQ	Q345R	A105N	AA	A350 LF2	A350 LF6 CL1	AH	A105N	A350 LF6 CL2
C5	A105N	A105N	AB	A350 LF2	A350 LF6 CL2	AL	A105N	A350 LF6 CL1
L5	A350 LF2	A350 LF2	AD	A105N	A350 LF2	XX	Others	Others

G	SEALS(1)							
CODE	SEAT INSERT	O-Ring	CODE	SEAT INSERT	O-Ring	CODE	SEAT INSERT	O-Ring
VV	VITON-B(2)	VITON-B	DH	DEVLON	HNBR	KT	PEEK	VITON-GLT
VH	VITON-B(2)	HNBR	DG	DEVLON	VITON-GF	KQ	PEEK	PTFE-Elgiloy Spring
VT	VITON-B(2)	VITON-GLT	DT	DEVLON	VITON-GLT	YV	N/A(3)	VITON-B
GG	VITON-GF(2)	VITON-GF	DQ	DEVLON	PTFE-Elgiloy Spring	YH	N/A(3)	HNBR
TT	VITON-GLT(2)	VITON-GLT	NV	NYLON	VITON-B	YG	N/A(3)	VITON-GF
HH	HNBR(2)	HNBR	NH	NYLON	HNBR	YT	N/A(3)	VITON-GLT
FV	RPTFE	VITON-B	NG	NYLON	VITON-GF	YQ	N/A(3)	PTFE-Elgiloy Spring
FH	RPTFE	HNBR	NT	NYLON	VITON-GLT	PQ	PCTFE	PTFE-Elgiloy Spring
FG	RPTFE	VITON-GF	NQ	NYLON	PTFE-Elgiloy Spring	XX	Others	Others
FT	RPTFE	VITON-GLT	KV	PEEK	VITON-B	(1)All seals on gaskets are Graphite. (2)Delta Ring. (3) Metal-to-Metal.		
FQ	RPTFE	PTFE-Elgiloy Spring	KH	PEEK	HNBR			
DV	DEVLON	VITON-B	KG	PEEK	VITON-GF			

H	TRIM MATERIAL						
CODE	BALL	SEAT RINGS	STEM	CODE	BALL	SEAT RINGS	STEM
002	A105N	A105N	AISI 4140	311	A182 F304	A182 F304	A182 F51(UNS S31803)
004	A105N	A182 F304	AISI 4140	401	A182 F316	A182 F316	A182 F316
012	A105N	A182 F6A	AISI 4140	403	A182 F316	A182 F316	A564 GR.630(UNS S17400)
020	A105N	A105N	A182 F6A	405	A182 F316	A182 F316	A182 F51(UNS S31803)
081	A694 F60	A105N	A694 F60	411	A182 F316	A182 F316	A182 FXM-19(UNSS20910)
101	A350 LF2	A350 LF2	A350 LF2	502	A182 F304L	A182 F304L	A182 F51(UNS S31803)
102	A350 LF2	A350 LF2	AISI 4140	603	A182 F316L	A182 F316L	A182 F51(UNS S31803)
104	A350 LF2	A182 F304	AISI 4140	650	A182 FXM-19(UNS S20910)	A182 FXM-19(UNS S20910)	A182 FXM-19(UNS S20910)
109	A350 LF2	A350 LF2	A564 GR.630(UNS S17400)	680	A564 GR.630(UNS S17400)	A564 GR.630(UNS S17400)	A564 GR.630(UNS S17400)
122	A350 LF2	A350 LF2	A182 F6A	701	A182 F51(UNS S31803)	A182 F51(UNS S31803)	A182 F51(UNS S31803)
278	A182 F6A	A182 F6A	A182 F6A	702	A182 F51(UNS S31803)	A182 F51(UNS S31803)	INCONEL 718(UNS N07718)
279	A182 F6A	A182 F304	A564 GR.630(UNS S17400)	751	A182 F53(UNS S32750)	A182 F53(UNS S32750)	A182 F53(UNS S32750)
280	A182 F6A	A182 F304	A182 F6A	752	A182 F53(UNS S32750)	A182 F53(UNS S32750)	INCONEL 718(UNS N07718)
301	A182 F304	A182 F304	A182 F304	761	A182 F55(UNS S32760)	A182 F55(UNS S32760)	A182 F55(UNS S32760)
303	A182 F304	A182 F304	A564 GR.630(UNS S17400)	XXX	Others	Others	Others

I	TRIM COATING			J	BOLTS & NUTS				
CODE	BALL	SEAT RINGS	STEM/TRUNNION	CODE	BOLT	NUT	CODE	BOLT	NUT
0	N/A	N/A	N/A	B1	A193 B7M	A194 2HM	N5	A320 B8M CL.2	A194 Gr.8M-S1
1	ENP	ENP	ENP	B2	A193 B7	A194 2H	N6	A320 B8M CL.1	A194 Gr.8MA
B	Stellite*	Stellite*	ENP	B3	A320 L7M	A194 7M	XX	Others	Others
L	Chrome Carbide*	Chrome Carbide*	ENP	B4	A320 L7	A194 Gr.7			
M	Tungsten Carbide*	Tungsten Carbide*	ENP	B5	A193 B8M	A194 Gr.8M			
P	NiCrMoCu*	NiCrMoCu*	ENP	B6	A193 B8	A194 Gr.8			
X	Others	Others	Others	B7	A193 B16	A194 Gr.7			
*Ball and seat rings sealing surface.				B8	A320 L7	A194 Gr.4			

K	SPECIAL REQUIREMENTS, MISC (MULTIPLE CHOICE)	
CODE	SPECIAL NOTES	
E-	Specify distance from valve centerline to top of power operator mounting flange for direct-buried ball valve. Example, E2500 means the specify distance is 2500mm.	
K	Anti-corrosion, acid-resisting reqs are in compliance with NACE MR0103, NACE MR0175, ISO 15156. Please provide detailed medium composition.	
D	Double piston effect (Single piston effect (self-release) seats are supplied as a standard feature).	
SD	Single piston for upstream and double piston for downstream (self-release).	
B-	Bolts & nuts coating, BE: ENP, BZ: Zinc Plating, BT: PTFE, BC: Cadmium+PTFE.	
X	Others special requirements.	

Notes: If you are uncertain about some categories, we will make suggestions based on your working conditions or your special requirement. The item marked with default will be used if no item is selected in that category unless it doesn't meet the working requirements.